

## TOYOTA PRIUS ZVW51 DC-DC CONVERTER CIRCUIT ANALYSIS REPORT

**June, 2016.** This sixty-five page document is one of six reports, each analyzing various segments of the ZVW51 system. This report is focusing on the PCB and its detailed circuits analysis. PCB structural details with various dimensions, component list, block diagram, detailed circuit schematic diagram and transformer inductance measurement results are included.

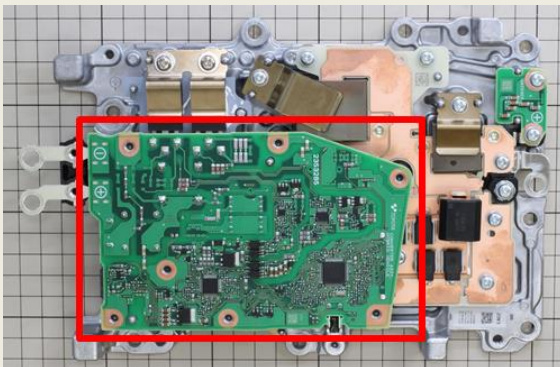

**Control board**

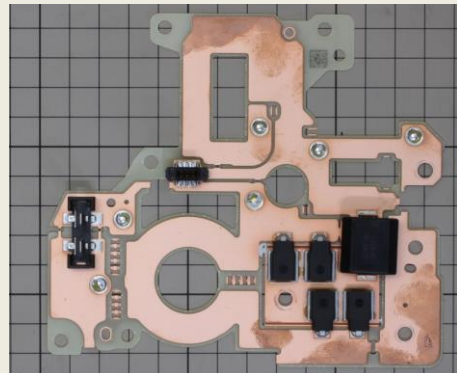

**Transformer board**

This DC-DC converter is produced by Toyota Industrial Corporation (TICO). It consists of three boards (control board, transformer board & smoothing board). According to TICO it is realized 50% volume reduction and 60% weight reduction. The system has the following main features:

1. The Cu thickness in the transformer board is 4 to 5 times higher than what was found in conventional boards.
2. Printed coil inductor is used.
3. Control is preformed by ASIC (TICO) and general MCU (STMicro).
4. The number of rectifier diodes found in this design is fewer than what was found in the previous generations.

**Note:**

The listed report price may not be accurate as it decreases over time.

Please contact us for current report pricing [info@ltecusa.com](mailto:info@ltecusa.com)

15G-0007-1

The block diagram of the Toyota Prius ZVW51 system, and the corresponding LTEC analysis reports are listed below:

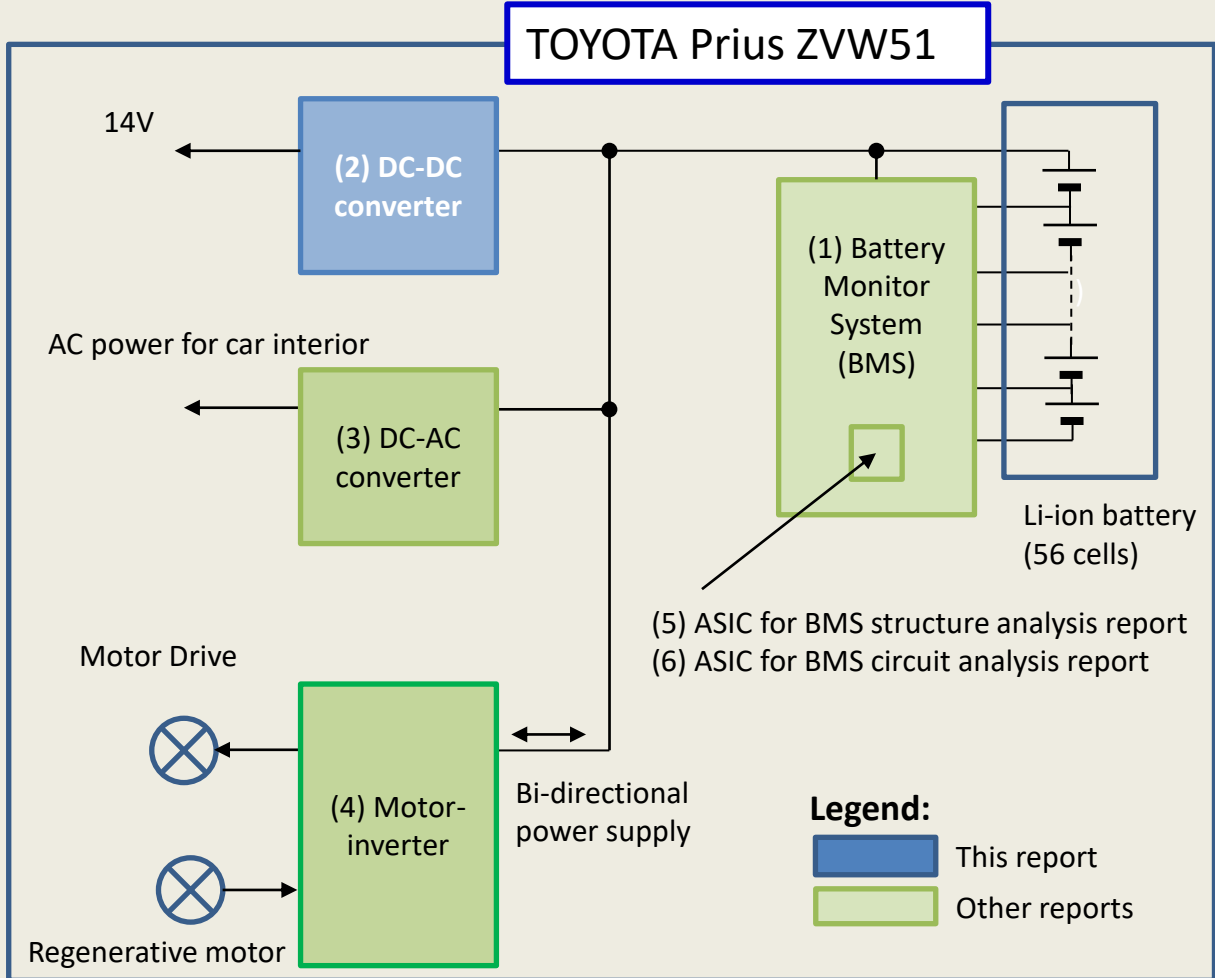

### Family of LTEC analysis reports related to the ZVW51 system

### Report No.

1. BMS PCB circuit analysis report analysis report	15G-0006-1
2. DC-DC converter PCB circuit (this report)	15G-0007-1
3. DC-AC converter PCB circuit analysis report	16G-0001-1
4. Motor-inverter PCB circuit analysis report	15G-0008-1
5. ASIC for BMS structure analysis report	15G-0013-1
5. ASIC for BMS circuit analysis report	15G-0005-1

15G-0007-1



LTEC Corporation US Representative Office  
No.203 2880 Zanker Road San Jose, CA 95034

Phone: (408) 432-7247

www.ltecusa.com Contact: info@ltecusa.com

Examination of the control board and the transformer board, the subject of this report, leads to our conclusion that the use of ASIC, micro-controller, and embedded inductor, along with other features, represents a well thought-out design that leads to significant size reduction and cost savings.

In reference to Page 2, all six constituent elements of the ZVW51 system, analyzed and reported on by LTEC, reflect that overall, the Toyota Prius ZVW51 system is an exceptionally well thought-out compact, highly cost-effective design.

\*\*\*\*

## Table of Contents

	<b>Page</b>
1. Analysis summary	4
2. Components	8
3. Teardown	9-28
4. Component details	29-31
5. Function block identification	32-34
6. Schematic	35-38
7. Component list	39-50
8. PCB interface connector details	51-55
9. Sensor details	56
10. Transformer	57-63
11. PCB structure (thickness & metal size)	64-65

15G-0007-1

