

CIRCUIT ANALYSIS REPORT OF THE TOYOTA PRIUS ZVW51 DC-AC CONVERTER FOR CAR INTERIOR AC OUTLET

June, 2016. This seventy-three page document is one of six reports, each analyzing various segments of the ZVW51 system. This report is focusing on the PCB and its detailed circuits analysis. PCB structural details with various dimensions, component list, block diagram, detailed circuit schematic diagram, transformer inductance measurement, noise countermeasures and cooling mechanism analysis are included.

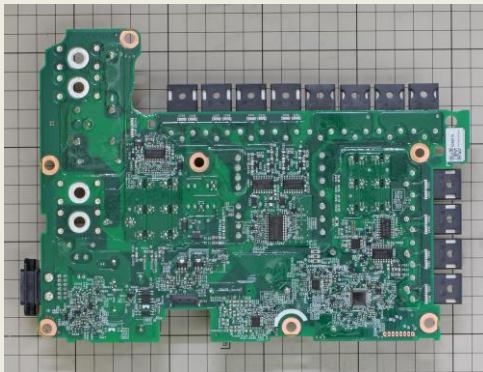

Control board

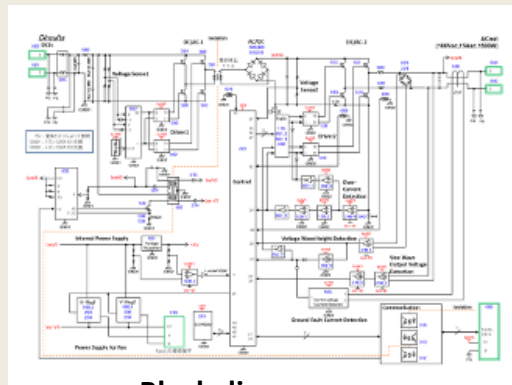

Block diagram

This DC-AC converter is produced by Toyota Industrial Corporation (TICO). The company announced 30% volume reduction as a result of improved component and cooling fan layout. The system has the following main features:

1. Discrete power devices (IGBT) are used.
2. Gate driver ASIC (TICO) are implemented. The entire system is controlled by MCU.
3. Built in output short circuit protection
4. Forced air cooling system

Note:

The listed report price may not be accurate as it decreases over time.

Please contact us for current report pricing info@ltecusa.com

16G-0001-1

The block diagram of the Toyota Prius ZVW51 system, and the corresponding LTEC analysis reports are listed below:

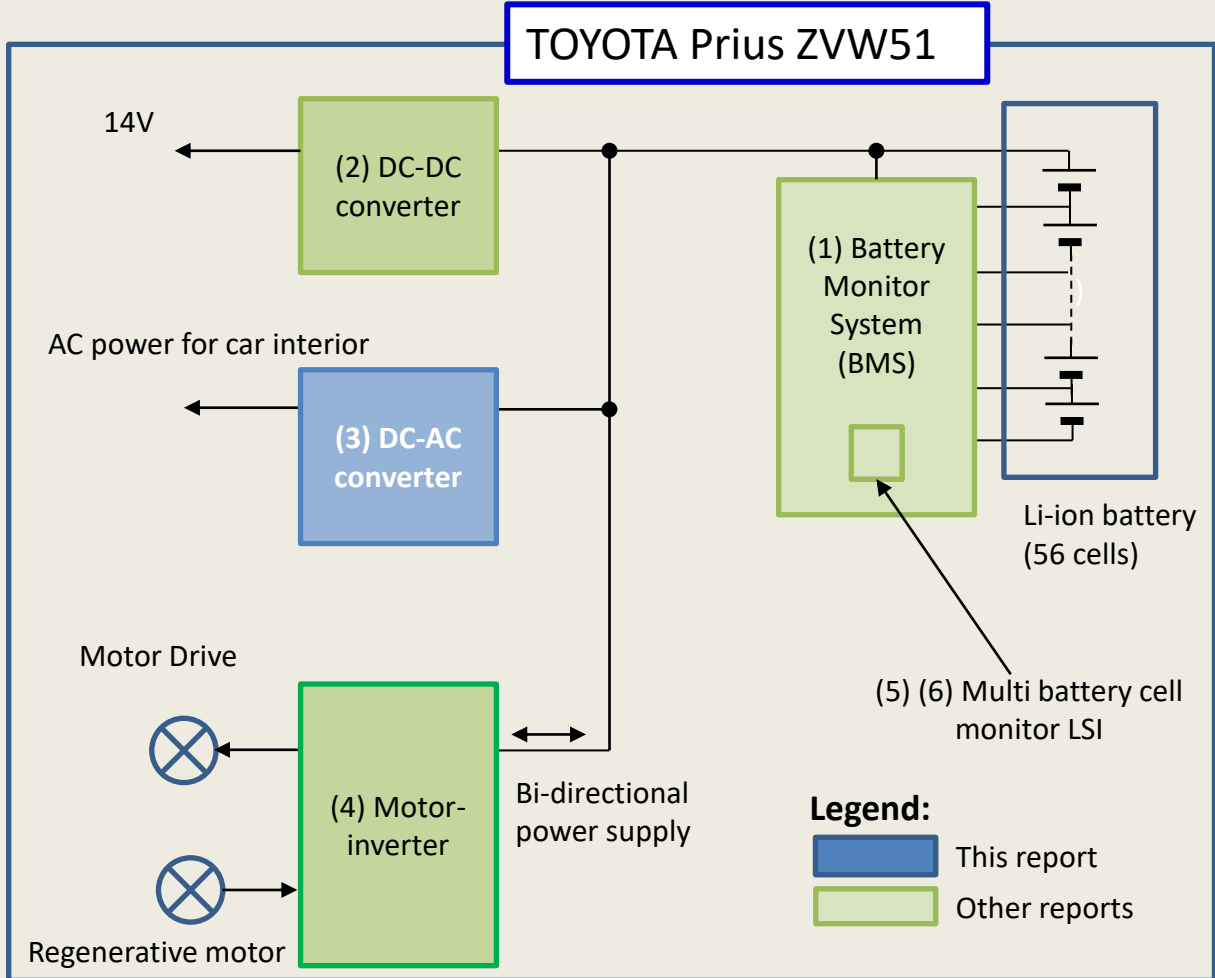

Family of LTEC analysis reports related to the ZVW51 system

Report No.

- | | |
|--|------------|
| 1. BMS PCB circuit analysis report analysis report | 15G-0006-1 |
| 2. DC-DC converter PCB circuit analysis report | 15G-0007-1 |
| 3. DC-AC converter PCB circuit analysis report (this report) | 16G-0001-1 |
| 4. Motor-inverter PCB circuit analysis report | 15G-0008-1 |
| 5. ASIC for BMS structure analysis report | 15G-0013-1 |
| 5. ASIC for BMS circuit analysis report | 15G-0005-1 |

16G-0001-1



Examination of the control board, the subject of this report, leads to our conclusion that the use of gate-driver ASIC on this PCB, and the utilization of advanced micro-controller for system supervisory and control, represent a well thought-out design that leads to significant size reduction and cost savings.

In reference to Page 2, all six constituent elements of the ZVW51 system, analyzed and reported on by LTEC, reflect that overall, the Toyota Prius ZVW51 system represents an exceptionally well thought-out compact, highly cost-effective design.

Table of Contents

	Page
1. Analysis summary	3-5
2. Components	6
3. Teardown	7-16
4. Component details	17-21
5. Function block identification	22
6. Schematic diagram	23-26
7. Component list	27-42
8. PCB interface connector details	43-44
9. Sensor details	45
10. Transformer	46-47
11. PCB structure (thickness & metal sizes)	48-61
12. Cooling mechanism	62-70
13. Countermeasures to reduce switching noise	71-75

16G-0001-1

